

# ASPEN UL Recognized 19-24-1001 Miniature Rotary Compressor

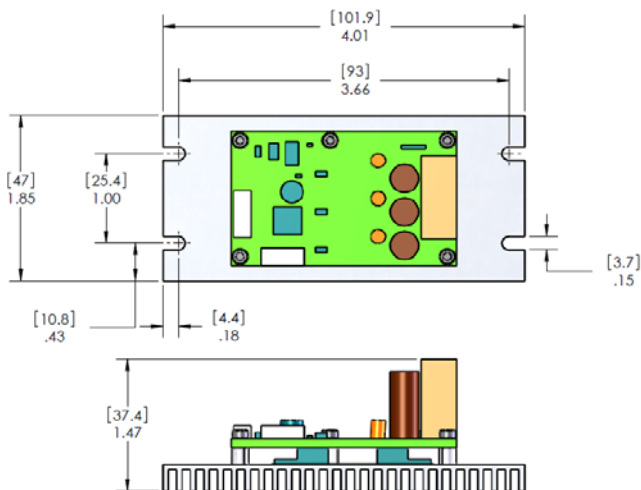

UL File Number	SA32332
Refrigerant	HFC-134a
Oil Type	Emkarate POE RL 68H
Oil Quantity	Factory Charged With 21cc's of Emkarate RL68H POE Oil
Motor	Brushless DC Thermally Protected
Voltage	24 Vdc (nominal)
Voltage Range	20 – 30 Vdc
Max Current	9.5 Amps Continuous
Compressor Displacement	1.9 cc
Compressor Speed	Variable
Speed Range	2100 – 6500 RPM
Compressor Weight	680 g
Evaporator Temperature Range	0–75°F (-18–24°C)
Condenser Temperature Range	80-160°F (27-71°C)
Max Discharge Temp.	265°F (130°C)
Max Compression Ratio	8:1
Max Compartment Temp.	130°F (54°C)
Suction Port Size	0.25" ID Cup
Discharge Port Size	0.25" OD Tube
Suction/Discharge Tube Orientation	180° Standard Custom Available
Compressor Mounting	Optional Bracket Available
Motor Drive Type	Sensorless
Analog Voltage Speed Command (Linear)	0 - .6 VDC = OFF .70 VDC = ~2100 RPM 4.5 VDC = ~6500 RPM
Drive Board Footprint	1.5" x 2.5"
Drive Board Weight	1.0 oz (28 g)
Drive Board Heat Sink	Anodized Aluminum
Heat Sink Footprint	1.85" x 4.0"
Heat Sink Weight	1.7 oz (46 g)

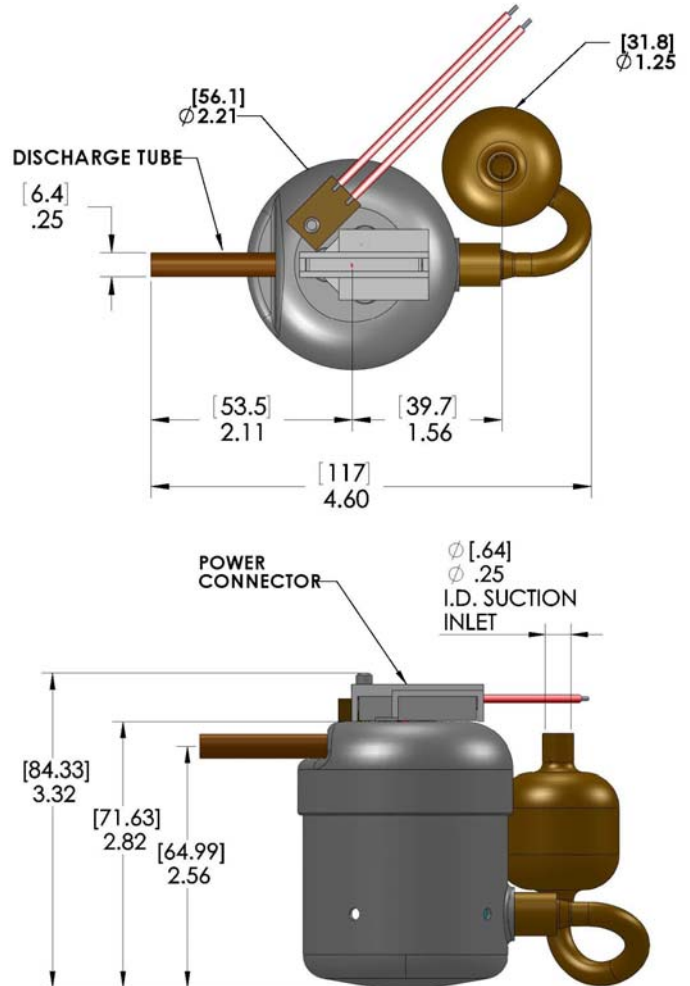

## Application Notes:

1. Drive Board must not be subject to corrosive or wet environments. Drive board is thermally protected, however continuous airflow over the drive board and heat sink is recommended.
2. Compressor is supplied with 21cc's of Emkarate RL68 POE oil. Additional oil may be required if operating compressor in systems with large internal volumes or areas that oil will gather prior to being returned to the compressor

# ASPEN 19-24-1001

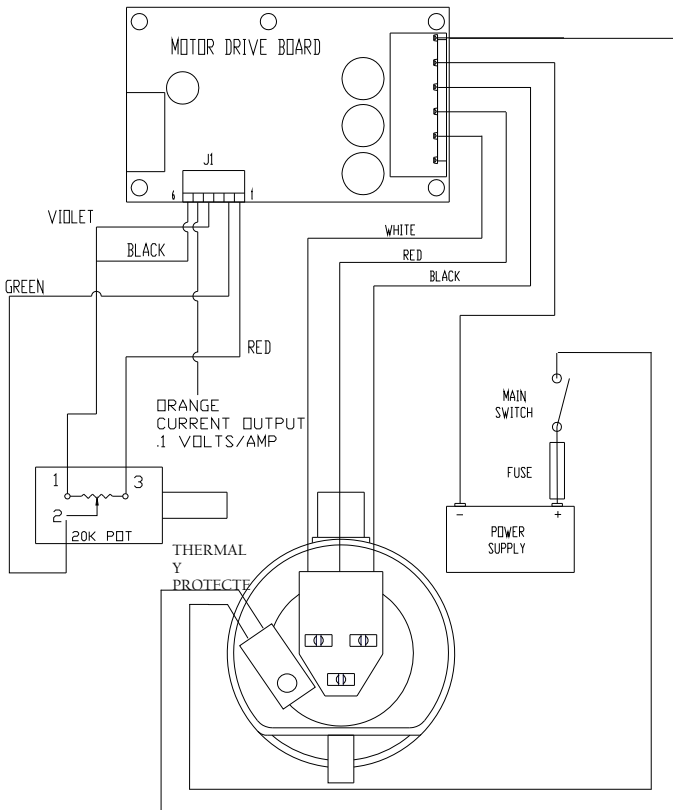

**Wiring Option 1** (User supplied potentiometer)

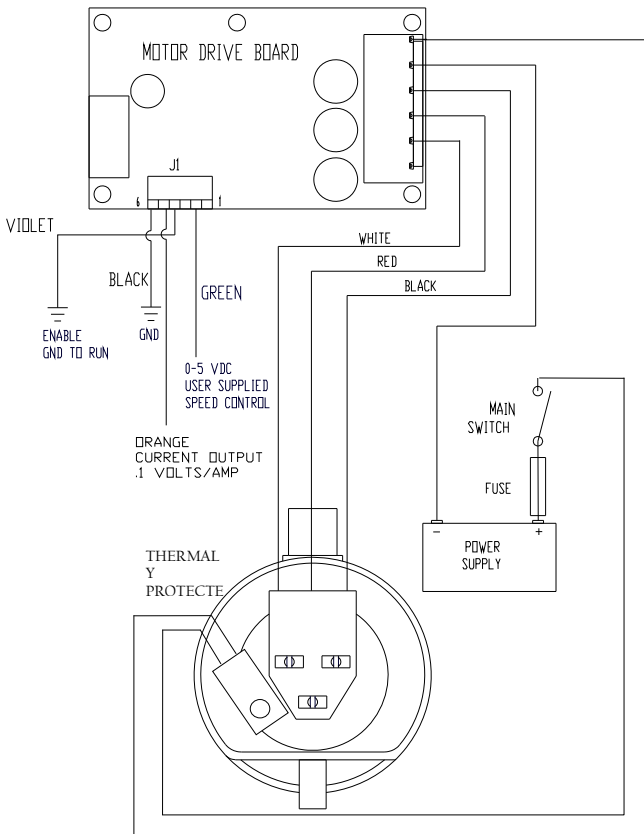

**Wiring Option 2** (User supplied speed input voltage)



Exclusive sale by



**Termotek AG**  
Im Rollfeld 6  
D 76532 Baden-Baden  
Germany  
Phone: +49 7221 9711-0  
Fax: +49 7221 9711-111  
www.termotek-ag.com  
info@termotek-ag.com